

Assembly Guide

SweetSpot One



Overview



Kuietly Does It

Up to 30dB Sound insulation.



Interior Acoustics

Carefully designed with 100% recycled felt absorption.



Optimised Ventilation

Twin ultra-quiet fans.



Lighting

Long-life energy efficient LED lighting.



Built-in Desk

Durable Marine grade plywood.



Power Socket

Built-in socket with one Schuko power and two USB charging.

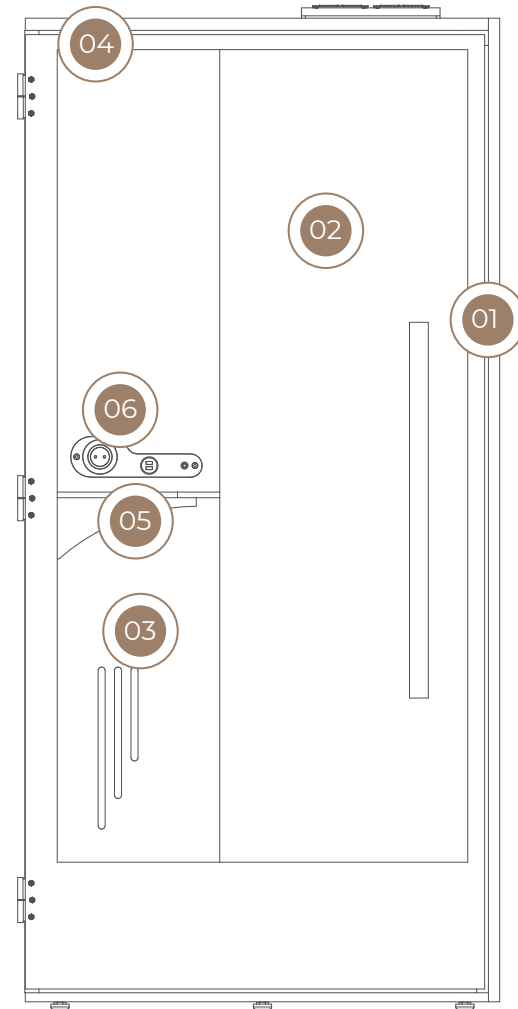

Inside the box

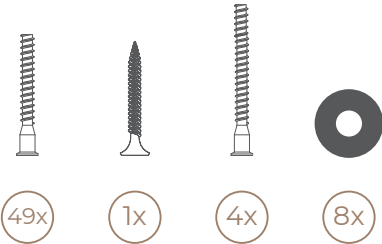

Necessary tools



01

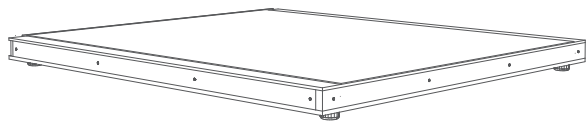

02

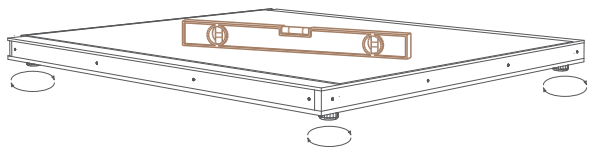

Adjust feet to level floor

03

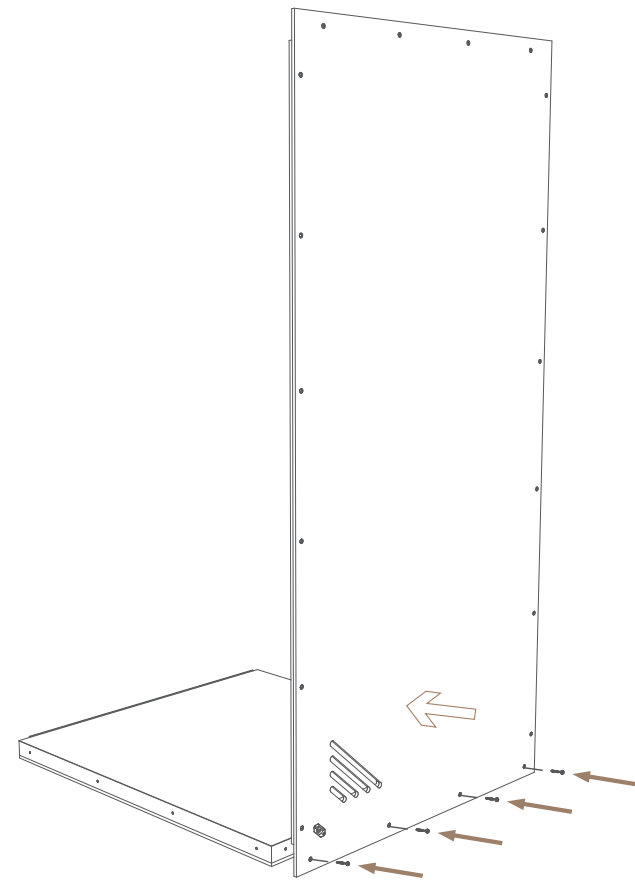

04

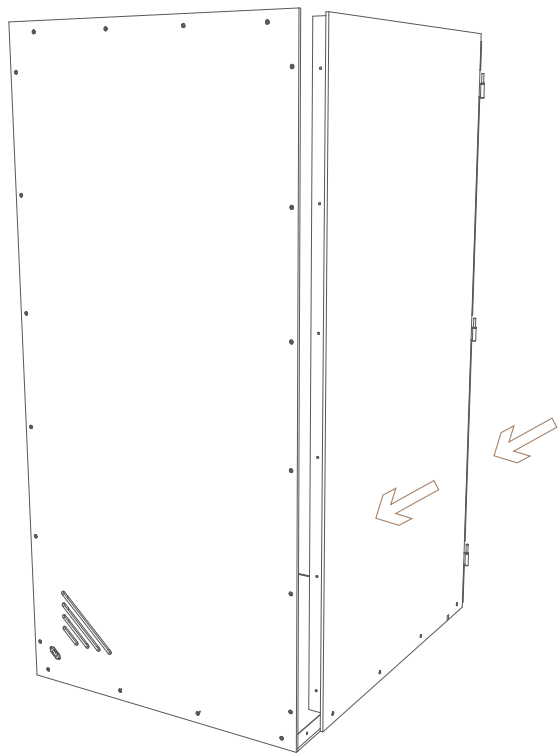

05

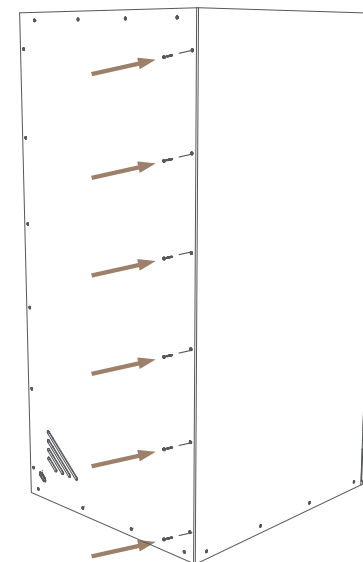

06

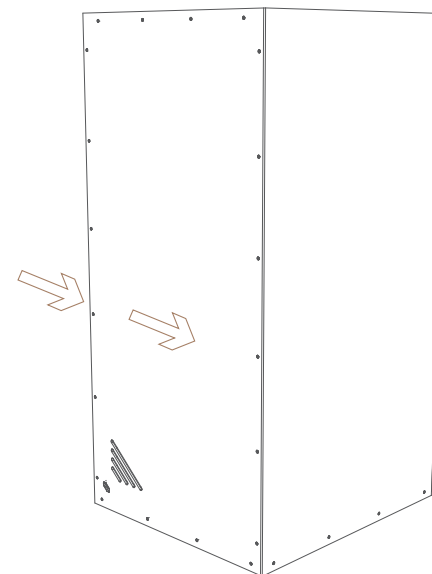

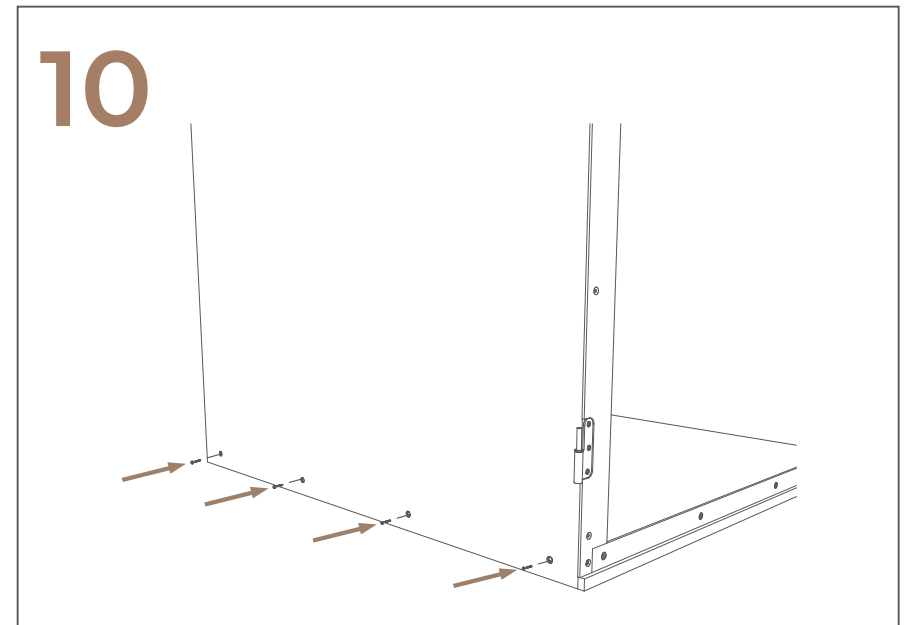
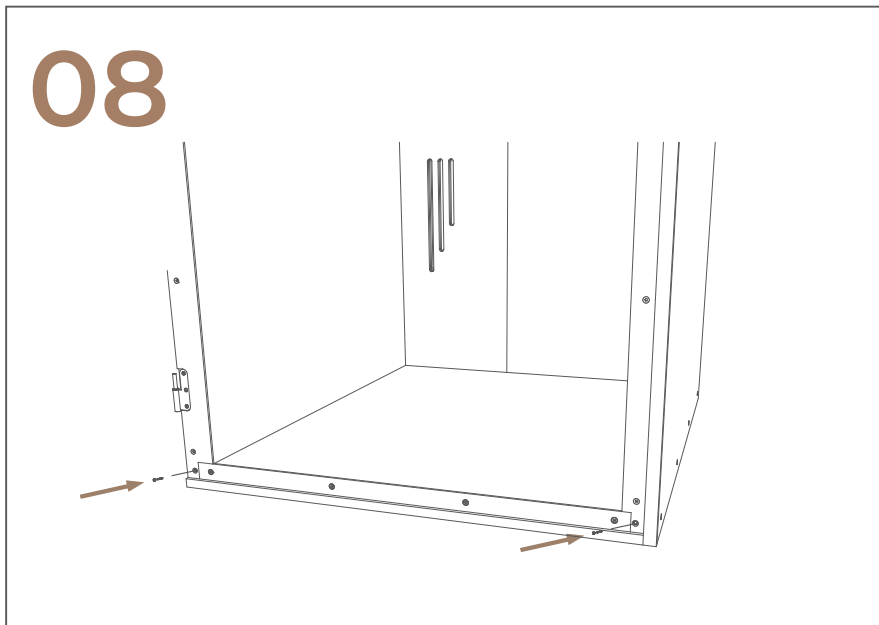
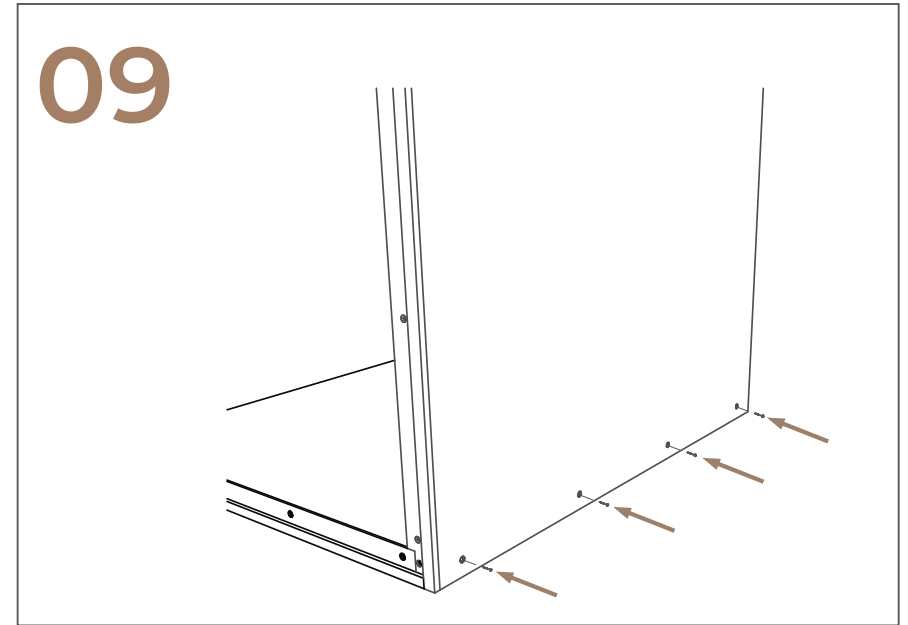
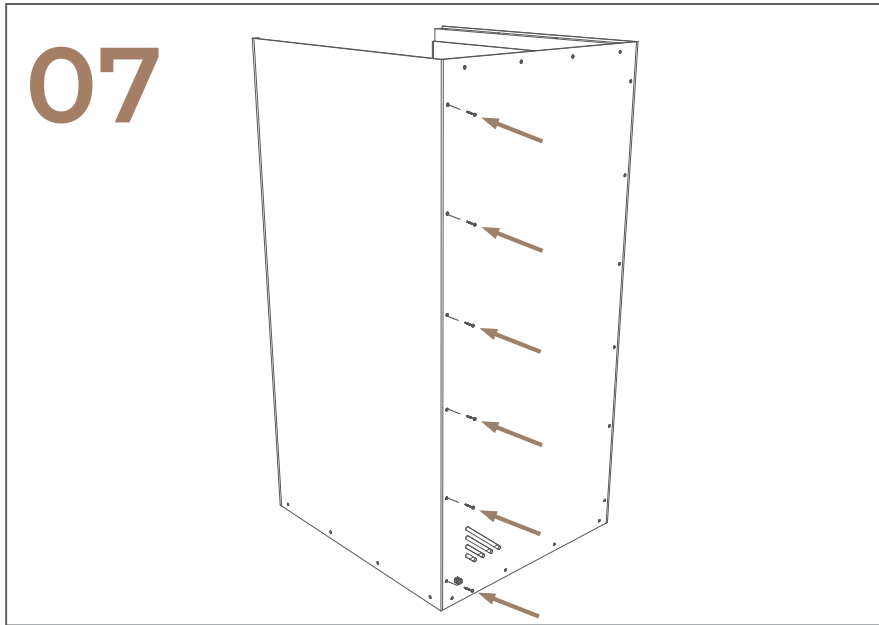

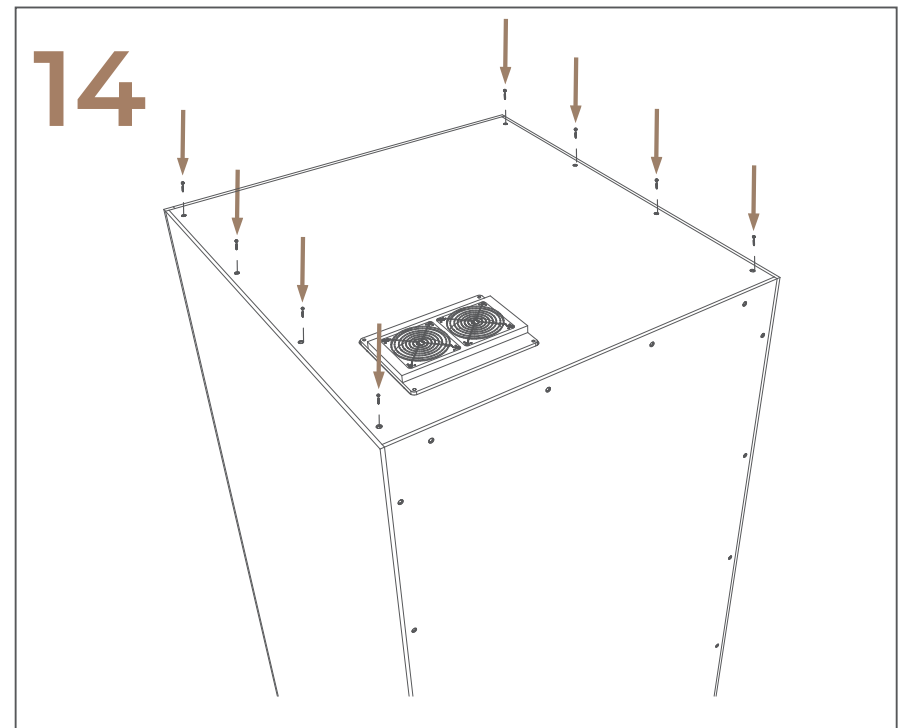
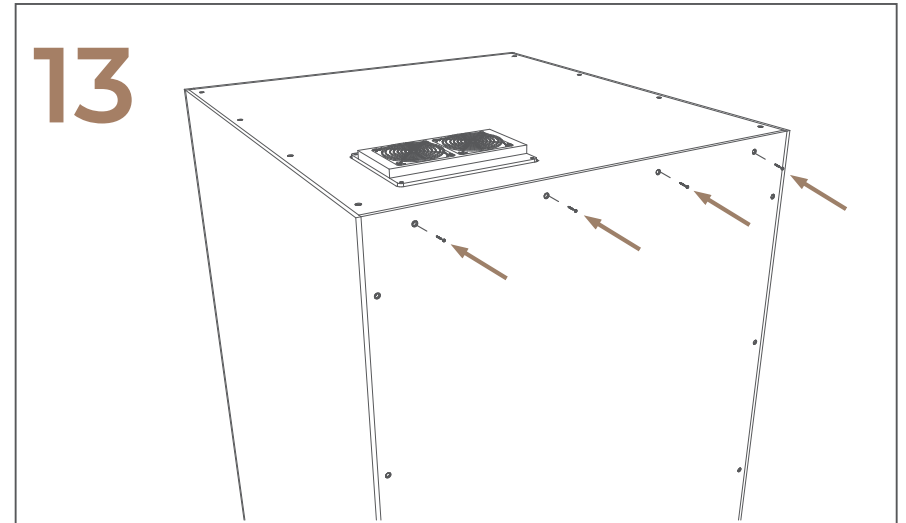
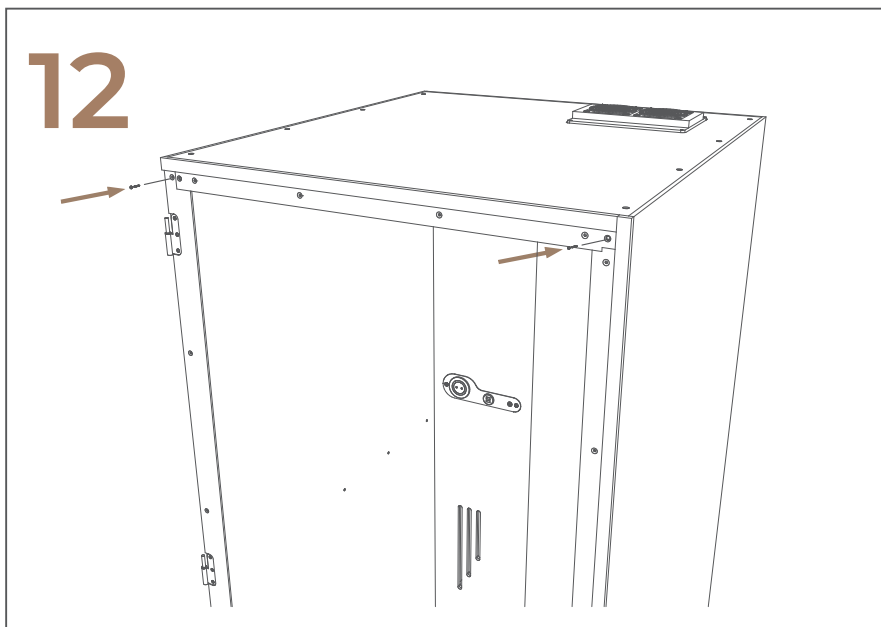
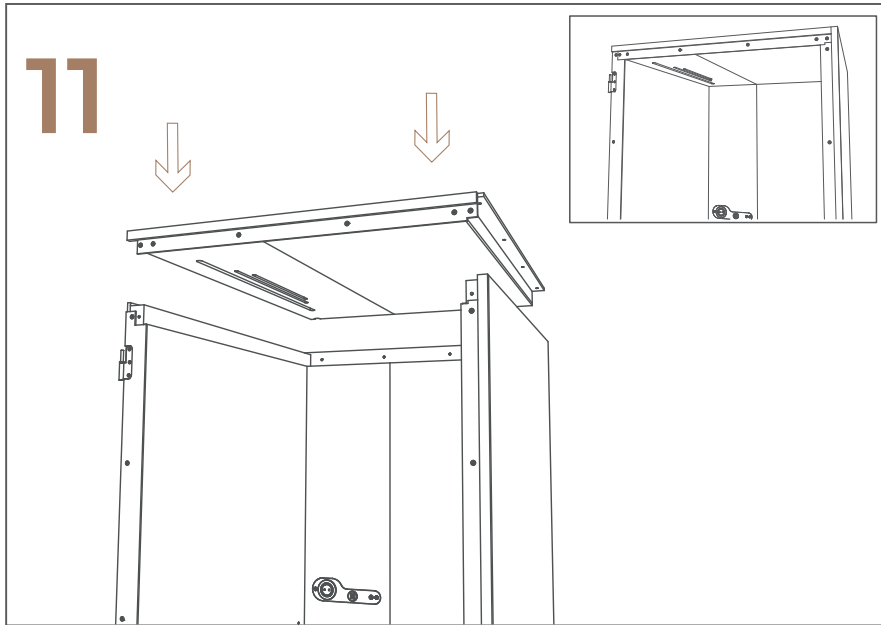

15

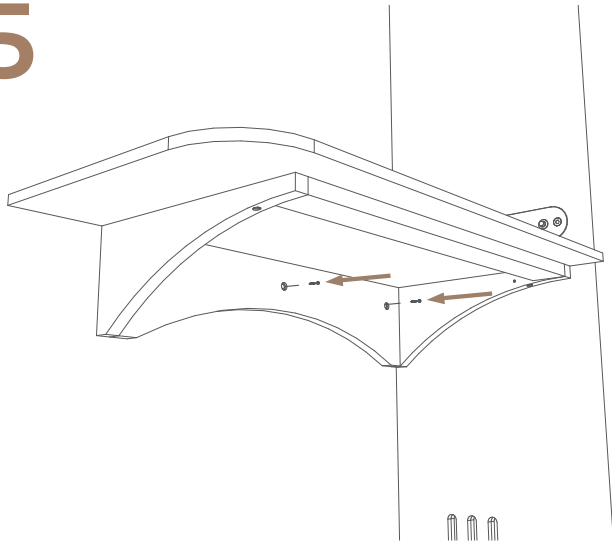

16

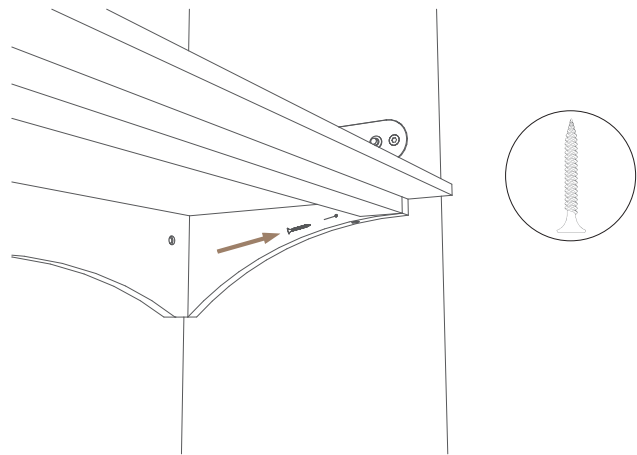

17

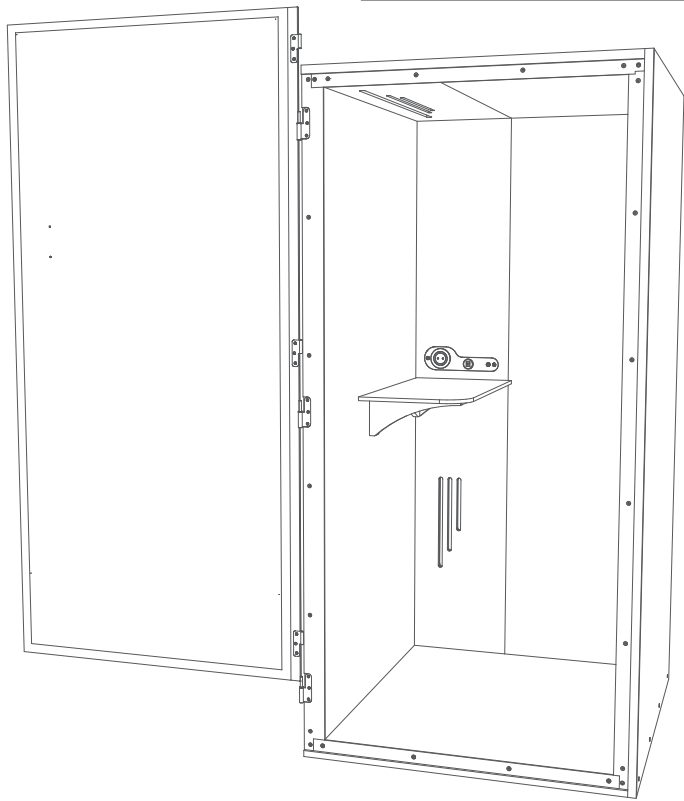
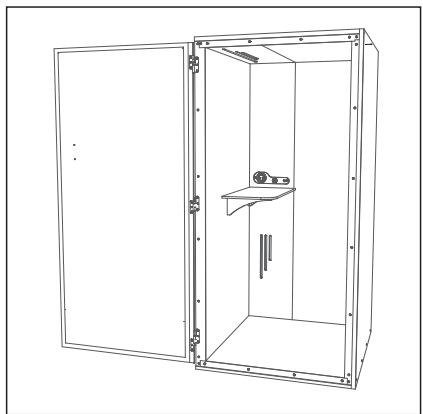

18

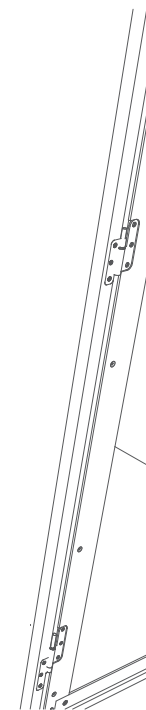
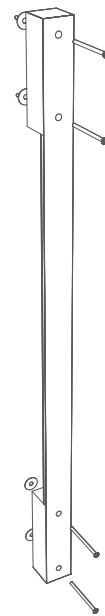
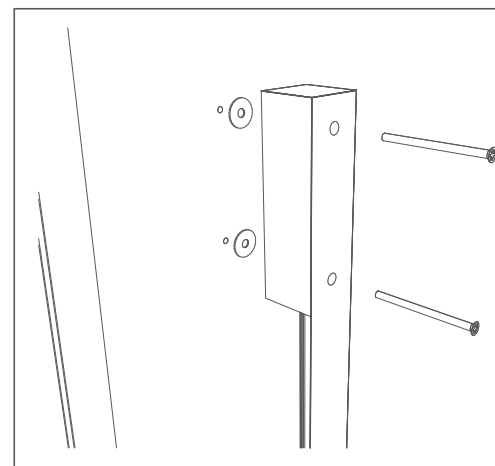

Enjoy your new space!

Kuietly

FOLLOW US



www.kuietly.com